

# High Power Programmable DC Power Supplies

## HPS Series



The HPS Series Programmable DC Power Supplies provide 20 kW of clean output power and high efficiency in a compact 3U form factor. These power supplies are well equipped for ATE system applications requiring a wide output voltage up to 1500 V. Multiple power supplies can be combined in parallel to increase the total output power to 160 kW.

The 5-inch touchscreen offers intuitive control while displaying both set and measured values including simulated internal resistance. The script function enables the power supply to output a sequence of user-defined voltage/current steps based on a set of written commands.

Additionally, built-in protection features including under voltage protection help prevent damage to the power supply and the device under test. Adjustable voltage/current slew rates and

configurable output on/off timer functions enhance user control. LabVIEW™ drivers are provided to simplify instrument control from a PC. Output voltage and current can be logged directly to a USB flash drive.

### Applications

- Testing photovoltaic components including inverters and battery charge controllers
- Relay and component device testing
- Various applications in aerospace, electric vehicle (EV), and green technology industries
- Manufacturing and production test

### Features and benefits

- 5-inch TFT touchscreen display for intuitive control
- High power density, 20 kW in a 3U form factor
- Efficiency up to 94%
- Built-in voltage and current measurement
- Master/slave mode provides up to 160 kW of output power with 8 units connected in parallel
- Galvanically isolated analog control and monitoring interface
- OVP, OCP, OPP, UVP (under voltage protection), and key lock function
- Configurable voltage and current rise time
- Fast transient response time < 3 ms
- Thermostatically-controlled fans help minimize noise
- Simulate the output of photovoltaic arrays
- Remote sense to compensate for voltage drop
- Datalogging directly to a USB flash drive
- Output on/off timer
- RS232 and LAN interfaces
- LabVIEW™ drivers included
- 3-phase 208 VAC or 400 VAC input configurations available\*

\*See ordering information section on page 5

Model	HPS20K800	HPS20K1500
Max. Output Voltage	800 V	1500 V
Max. Output Current	25 A	13.4 A
Max. Output Power	20 kW	

## Operation highlights

### Generate custom output sequences (Script function)

The script function provides a simple way to output a sequence of user-defined voltage/current steps. Similar to list mode, this function offers greater flexibility by supporting more complex output curves. The script function is useful for generating custom output sequences in production test and other automated test applications.

#### Script example

Command	Comment
i 10	Current limit set to 10 A
u 600	Set output voltage to 600 V
RUN	Enable the output
WAIT	Wait for manual trigger
delay 15	15 ms delay
u 550	Set output voltage to 550 V
delay 20	20 ms delay
u 500	Set output voltage to 500 V

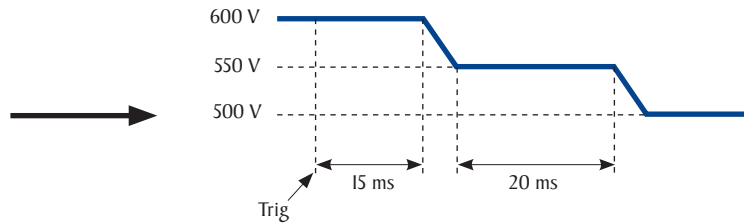

### Additional script function capabilities

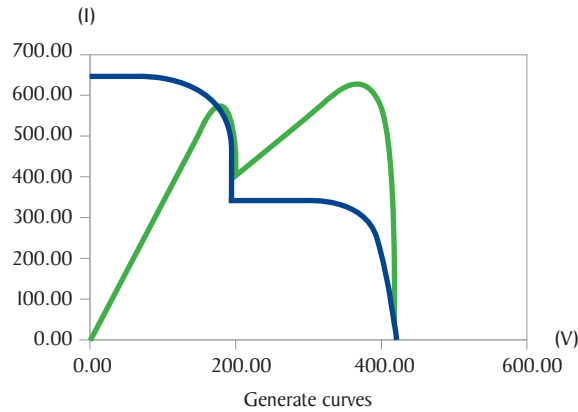
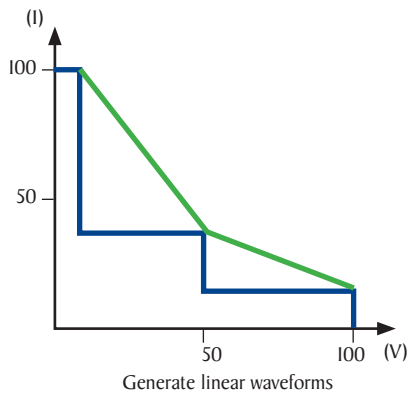

### Master/Slave operation

Up to 8 HPS Series power supplies can be connected in parallel delivering 160 kW of total output power.

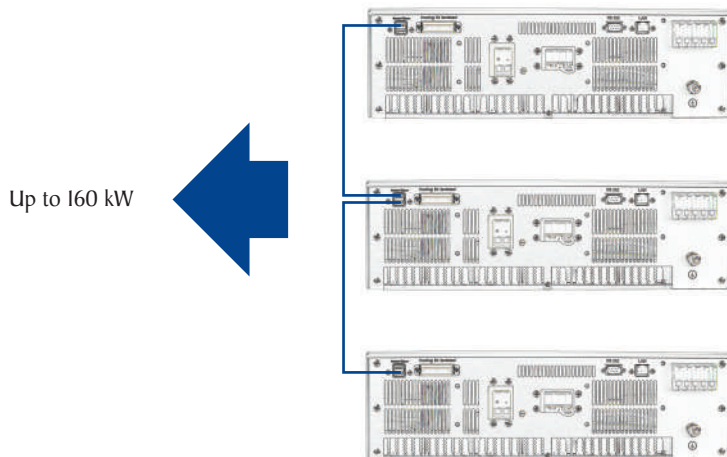

### Intuitive front panel operation

The 5-inch touchscreen display is intuitive and easy to navigate. Measured voltage, current, power, and internal resistance values are displayed along with set parameters and operating mode.

B&K Precision HPS10K50			
Monitor		Preset	
V	0 mV	V	0 mV
I	0 mA	I	0 mA
P	0 W	Local	Standby
R	0 mΩ	Mode	VC
		On	

## Front panel

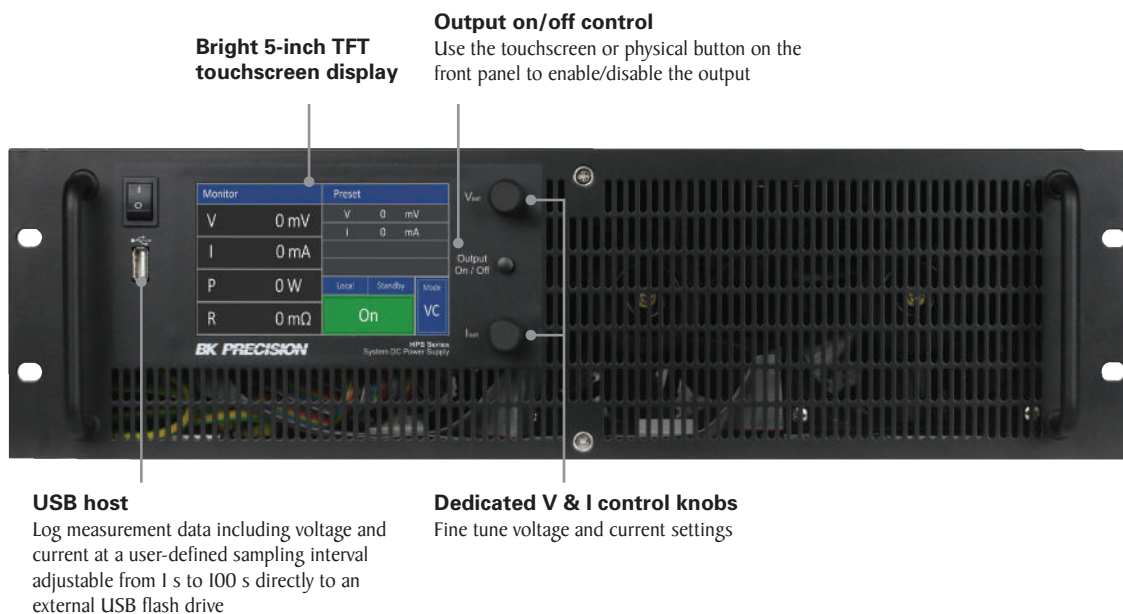

## Rear panel

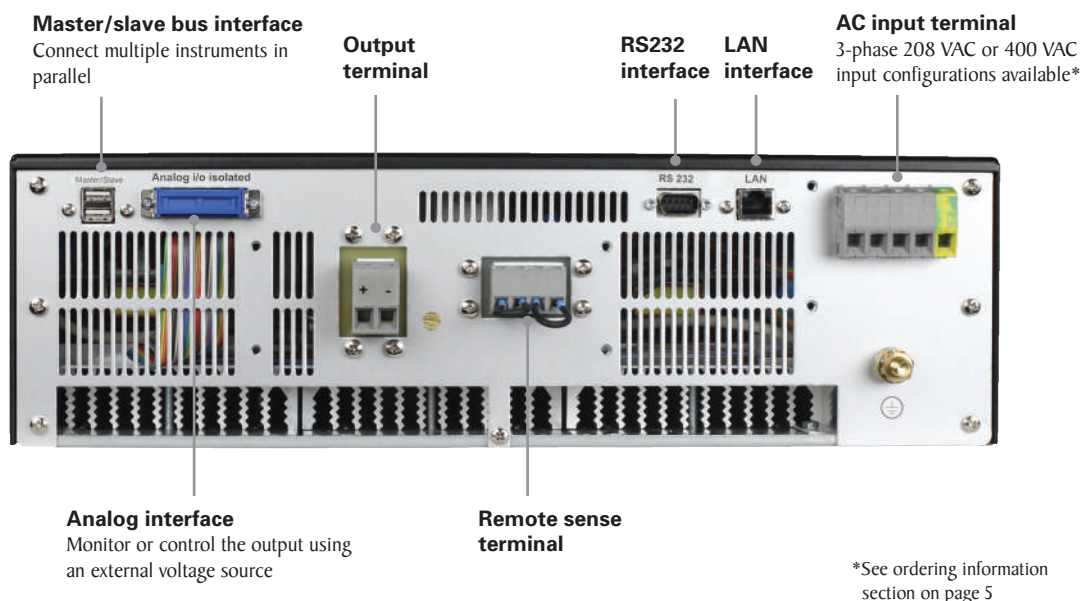

## Specifications

Note: All specifications apply to the unit after a temperature stabilization time of 15 minutes over an ambient temperature range of 23 °C ± 5 °C. Specifications are valid for single unit operation only.

Model		HPS20K800	HPS20K1500
<b>Output Rating</b>			
Output Voltage		0 to 800 V	0 to 1500 V
Output Current		0 to 25 A	0 to 13.4 A
Output Power		20 kW	
<b>Line Regulation</b>			
Voltage		160 mV	300 mV
Current		5 mA	3 mA
<b>Load Regulation</b>			
Voltage		420 mV	770 mV
Current		33 mA	27 mA
<b>Ripple and Noise (20 Hz to 20 MHz)</b>			
Voltage p-p		350 mV	900 mV
Voltage rms		150 mV	200 mV
Current rms <sup>(1)</sup>		25 mA	12 mA
<b>Readback Resolution</b>			
Voltage Range	20 V to 99.99 V	10 mV	
	100.0 V to 999.9 V	0.1 V	
	1000 V to 1500 V	-	1 V
Current Range	0 A to 9.999 A	1 mA	
	10.00 A to 25 A	10 mA	
<b>Programming Accuracy</b>			
Voltage		≤ 800 mV	≤ 1.5 V
Current		≤ 50 mA	≤ 30 mA
<b>Output Response Time<sup>(2)</sup></b>			
Rise Time	Full Load	≤ 40 ms	≤ 6 ms
	No Load	≤ 10 ms	≤ 5 ms
Fall Time	Full Load	≤ 60 ms	≤ 25 ms
	No Load	≤ 10 s	≤ 1 s
<b>208 AC Input</b>			
Nominal Input Voltage		208 VAC	
Input Range		187 to 229 VAC	
Frequency		47 to 63 Hz	
Phase		3 phase	
<b>400 AC Input</b>			
Nominal Input Voltage		400 VAC	
Input Range		360 to 440 VAC	
Frequency		47 to 63 Hz	
Phase		3 phase	
<b>Protection</b>			
OVP	Range	0 to 960 V	0 to 1800 V

(1) When output power > 1.0% of full power.

(2) From 10% to 90% or from 90% to 10% of total voltage excursion.

General		
Remote Sense Compensation	80 V	150 V
Transient Response Time <sup>(3)</sup>	≤ 3 ms	
Command Response Time <sup>(4)</sup>	10 ms	
Efficiency <sup>(5)</sup>	94%	
Power Factor	> 0.7	
Output Terminal Isolation	2000 V	
Inrush Current <sup>(6)</sup>	76 A	
Leakage Current	< 35 mA	
I/O Interfaces	RS232, LAN, Analog (Galvanically isolated DB25)	
Analog Programming (typical)	Input impedance: 1 MΩ Maximum input voltage 25 V Response time < 10 ms	
Temperature Ratings	Operation	32 °F to 122 °F (0 °C to 50 °C)
	Storage	-4 °F to 158 °F (-20 °C to 70 °C)
Operating Humidity	< 80%	
Altitude	< 2000 m	
Environment	Installation category II, pollution degree 2	
Dimensions (W×H×D)	19" x 5.3" x 24.2" (482 x 132.5 x 614.7 mm)	
Weight	82 lbs (37 kg)	
Warranty	3 Years	
Standard Accessories	Test report & certificate of calibration	
<b>Regulatory Compliance</b>		
Safety	Low Voltage Directive (LVD) 2014/35/EU, EN61010-1:2010 + A1:2019	
Electromagnetic Compatibility	EMC Directive 2014/30/EU, EN61326-1:2013	

(3) Time for output voltage to recover within 0.5% ±25 mV of its rated output.

(4) Typical time required for output to begin to change following receipt of command data.

(5) At nominal line voltage and max load.

(6) Applies to rated input voltage. The inrush current only occurs when first connecting to the grid.

## Technical Drawings

Units are in mm

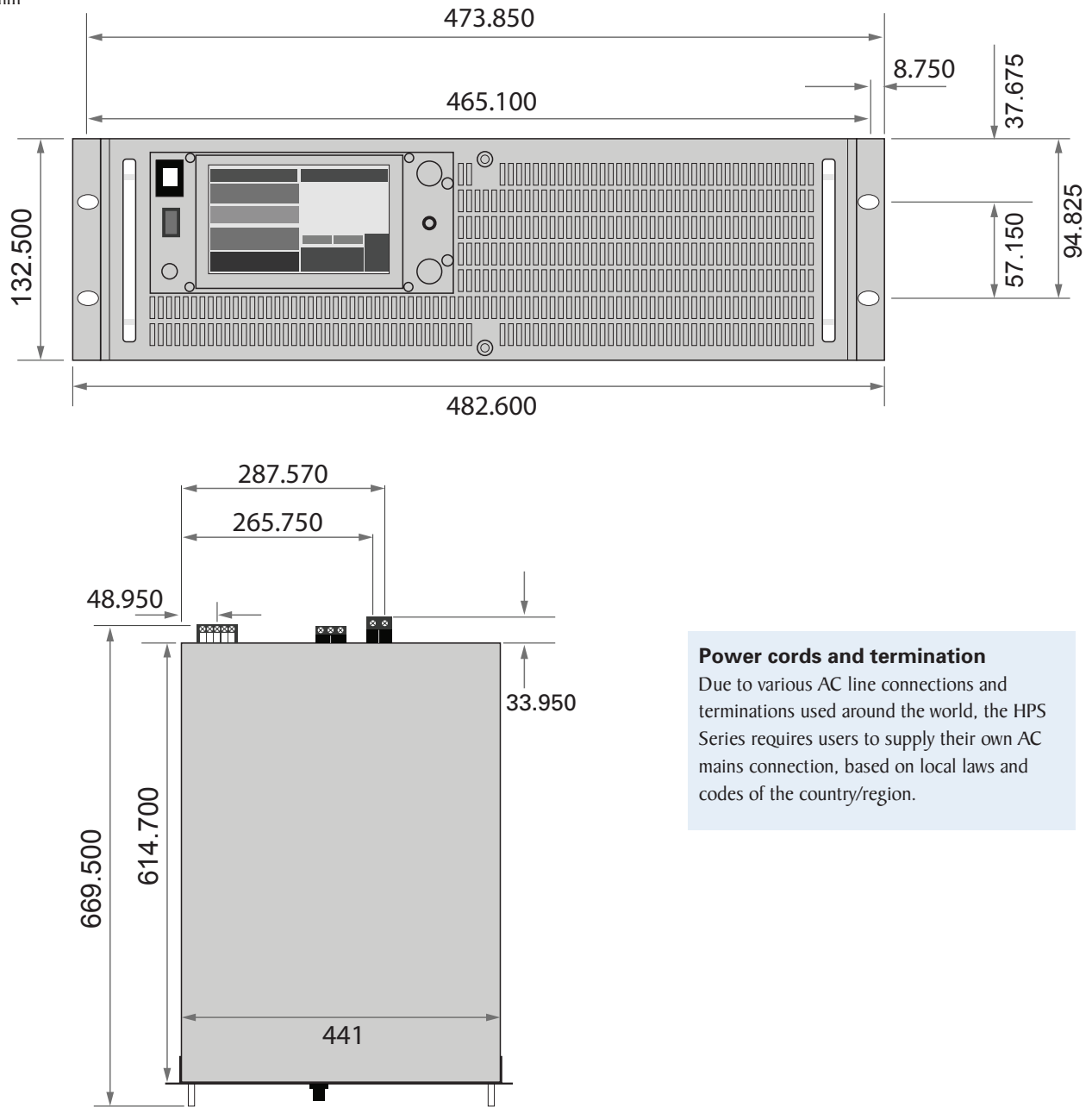

**Power cords and termination**  
Due to various AC line connections and terminations used around the world, the HPS Series requires users to supply their own AC mains connection, based on local laws and codes of the country/region.

## Ordering Information

### HPS Series

Model	Description
HPS20K800	800 V / 25 A / 20 kW DC Power Supply - 208 VAC Input
HPS20K800-400V	800 V / 25 A / 20 kW DC Power Supply - 400 VAC Input
HPS20KI500	1500 V / 13.4 A / 20 kW DC Power Supply - 208 VAC Input
HPS20KI500-400V	1500 V / 13.4 A / 20 kW DC Power Supply - 400 VAC Input

## About B&K Precision

For more than 70 years, B&K Precision has provided reliable and value-priced test and measurement instruments worldwide.

Our headquarters in Yorba Linda, California houses our administrative and executive functions as well as sales and marketing, design, service, and repair. Our European customers are most familiar with B&K through our French subsidiary, Sefram. Engineers in Asia know us through our B+K Precision Taiwan operation. The independent service centers in Singapore and Brasil service customers in Singapore, Malaysia, Vietnam, Indonesia and South America, respectively.



● B&K Precision group member ● Independent service center ● Service center location

## Quality Management System

B&K Precision Corporation is an ISO9001 registered company employing traceable quality management practices for all processes including product development, service, and calibration.

ISO9001:2015

Certification body NSF-ISR  
Certificate number 6Z241-ISR



## Video Library

View product overviews, demonstrations, and application videos in English, Spanish and Portuguese.

<http://www.youtube.com/user/BKPrecisionVideos>

## Product Applications

Browse all of our supported product and mobile applications.

<http://bkprecision.com/product-applications>