SCB-68

Getting Started

2023-09-08



Contents

SCB-68 Overview.....	3
What You Need to Get Started.....	4
Getting Started with the SCB-68.....	4
Using the SCB-68 in Direct Feedthrough Mode.....	7
Using the SCB-68 with Multifunction I/O Devices.....	8
Connecting Signal Sources to Analog Inputs.....	10
Fuse and Power Information.....	10
Where to Go from Here.....	11

SCB-68 Overview

This guide describes how to connect and use the SCB-68 with 68-pin or 100-pin data acquisition (DAQ) devices and other NI products with a 68-pin SCSI or VHDCI I/O connector. For a complete list of supported devices and available SCB-68 features, visit ni.com/r/scb68dev.



Note To use the SCB-68 with devices without analog input functionality, you must change the default switch setting. Refer to [Using the SCB-68 in Direct Feedthrough Mode](#) for more information.

Figure 1. SCB-68 Parts Locator Diagram

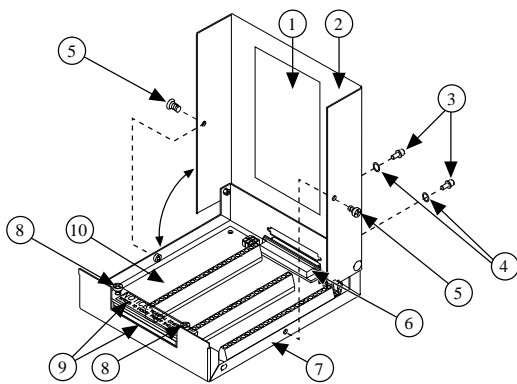

1. Quick Reference Label (Optional)
2. Top Cover
3. 68-Pin Connector Screws
4. Lock Washers
5. Shielding Screws
6. 68-Pin I/O Connector
7. Base
8. Strain-Relief Screws
9. Strain-Relief Hardware
10. SCB-68 Board Assembly

© 1994–2023 National Instruments Corporation. All rights reserved. Refer to the <National Instruments>_Legal Information directory for information about NI copyright, patents, trademarks, warranties, product warnings, and export compliance.

What You Need to Get Started

To set up and use your SCB-68, you need the following:

- SCB-68 68-pin shielded connector block kit(s)
- Compatible 68-pin or 100-pin DAQ device, and device documentation
- The correct cable(s) for your device, as listed at ni.com/r/scb68dev.
- Phillips #1 and #2 screwdrivers
- 0.125 in. flathead screwdriver
- 14–30 AWG wire
- Wire cutters
- Wire insulation stripper

Getting Started with the SCB-68

The following cautions contain important safety information concerning hazardous voltages and connector blocks.



Caution To avoid electrical shock, do not remove equipment covers or shields unless you are qualified to do so. Before removing the cover, disconnect any live circuit from the connector block.



Caution The chassis ground terminals on your SCB-68 are for grounding high-impedance sources, such as a floating source (1 mA maximum). Do not use these terminals as safety earth grounds.



Caution Do not connect hazardous voltages (≥ 42 V pk/60 V DC).

The following figure shows the SCB-68 board parts locator diagram.

Figure 2. SCB-68 Printed Circuit Board Diagram

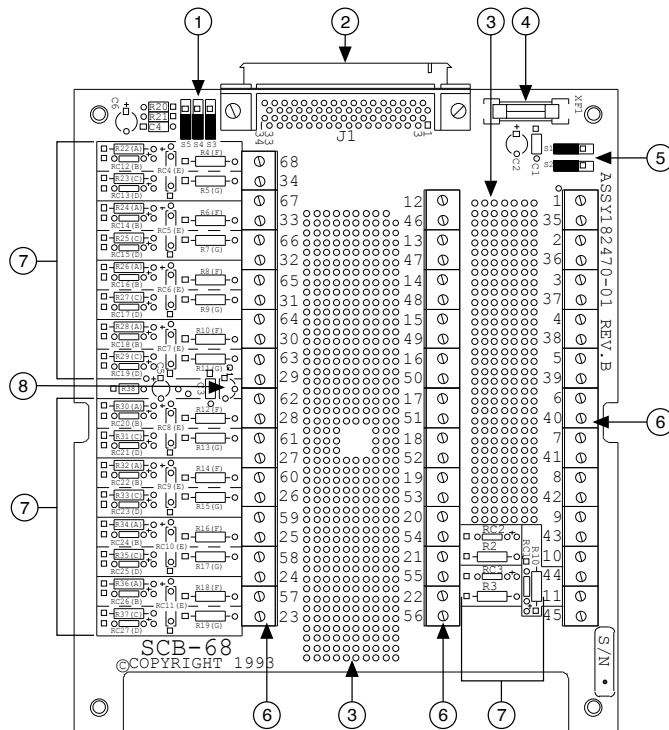

1. Switches S3, S4, and S5
2. 68-Pin I/O Connector
3. Breadboard Area
4. Fuse (800 mA, 250 V, 5 × 20 mm)
5. Switches S1 and S2
6. Screw Terminals
7. Signal Conditioning Areas
8. Temperature Sensor

To get started with the SCB-68, complete the following steps while referring to Figures 1 and 2. If you have not already installed your DAQ device, refer to the **DAQ Getting Started Guide** for instructions.

1. Disconnect the cable from the SCB-68, remove the shielding screws with a Phillips #1 screwdriver, and open the top cover.

2. Attach the quick reference label to the inside of the top cover as shown in Figure 1. You can find quick reference labels, which specify accessory pinout information for many compatible devices, by going to ni.com/r/scb68dev.
3. Configure switches for the signal types you are using, as explained in [Using the SCB-68 in Direct Feedthrough Mode](#) or [Using the SCB-68 with Multifunction I/O Devices](#).
4. Adjust the strain-relief hardware by loosening the strain-relief screws with a Phillips #2 screwdriver and sliding the signal wires through the front panel strain-relief opening. If you are connecting multiple signals, remove the top strain-relief bar and add insulation or padding if necessary.
5. Connect the wires to the screw terminals by stripping 6.35 mm (0.25 in.) of insulation, inserting the wires into the screw terminals, and securely tightening the screws with the flathead screwdriver to a torque of 0.5–0.6 N · m (4.43–5.31 lb · in.).
6. Reinstall the strain-relief (if removed) and tighten the strain-relief screws.
7. Close the top cover and reinsert the shielding screws to ensure proper shielding.



Caution Do not connect input voltages ≥ 42 V pk/60 V DC to the SCB-68. The SCB-68 is not designed for any input voltages ≥ 42 V pk/60 V DC, even if a user-installed voltage divider reduces the voltage to within the input range of the DAQ device. Input voltages ≥ 42 V pk/60 V DC can damage the SCB-68, all devices connected to it, and the host computer.

8. Connect the SCB-68(s) to the DAQ device using the appropriate cable(s) for your device. For a complete list of cabling options for supported devices, visit ni.com/r/scb68dev.
9. Launch Measurement & Automation Explorer (NI MAX), confirm that your DAQ device is recognized, and configure your device settings. Refer to the **DAQ Getting Started Guide** for more information.
10. (Optional) If you are going to take measurements with an MIO DAQ device, configure the SCB-68 as an accessory for a DAQ device using MAX by completing the following steps.

- a. In the left pane of MAX, expand **Devices and Interfaces**, then right-click your DAQ device and select **Properties** from the pull-down menu.
- b. Select the **Accessory** tab from the dialog box, select **SCB-68** from the pull-down menu, then select **Configure**.
For more information about configuring the SCB-68 for a DAQ device, refer to the **Measurement & Automation Explorer Help for NI-DAQmx**.

11. Test specific device functionality. Refer to the **DAQ Getting Started Guide** for detailed information about running test panels in MAX.

When you have finished using the SCB-68, power off any external signals connected to the SCB-68 before you power off your computer.

Using the SCB-68 in Direct Feedthrough Mode

NI 25xx, NI 4309, NI 65xx, NI 66xx, NI 67xx, and NI 78xx, and products without analog input functionality must use direct feedthrough mode. Move the switches to the direct feedthrough mode switch setting shown in the following table.

Table 1. Direct Feedthrough Switch Setting

Switch Setting	Description
	<p>Direct feedthrough mode—Move switches S1, S2, S3, S4, and S5 to the positions shown at left. In this mode:</p> <ul style="list-style-type: none"> ▪ All 68 signals from the device connect directly to screw terminals <p>Refer to the following figure for a detailed diagram.</p>

Figure 3. Direct Feedthrough Mode Switch Setting



Using the SCB-68 with Multifunction I/O Devices

You can take measurements with the SCB-68 and multifunction I/O (MIO) DAQ products, such as NI 60xx/61xx/62xx/63xx, in a number of ways. Switches S1 and S2 provide power to the signal conditioning area of the accessory. The SCB-68 has a temperature sensor for cold-junction compensation (CJC) to accommodate thermocouples; switches S3, S4, and S5 configure the temperature sensor for different analog input settings. The following table shows the different switch settings for MIO DAQ devices.

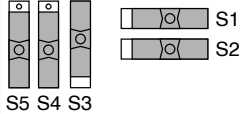
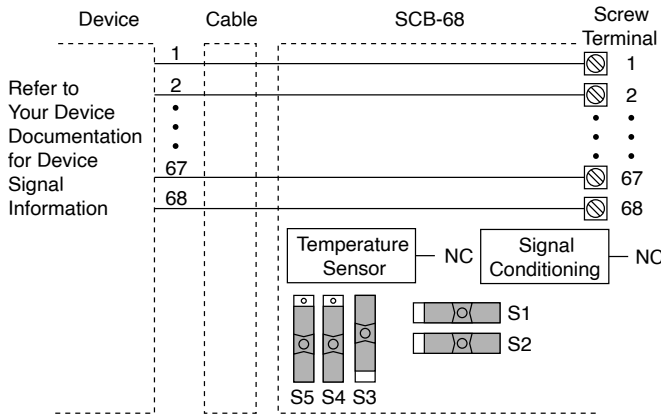
Table 2. MIO DAQ Device Switch Settings

Switch Setting	Description
	<p>MIO with disabled temperature sensor mode (default configuration) —Move switches S1, S2, S3, S4, and S5 to the positions shown at left. In this mode:</p> <ul style="list-style-type: none"> ■ The temperature sensor is not used. ■ AI 0 and AI 8 are available on screw terminals. ■ +5 V power provided to signal conditioning area of the accessory. <p>Refer to the following figure for a detailed diagram.</p>

Switch Setting	Description
	<p>MIO with single-ended temperature sensor mode—Move switches S1, S2, S3, S4, and S5 to the positions shown at left. In this mode:</p> <ul style="list-style-type: none"> ▪ The temperature sensor can be read using AI 0 in referenced single-ended (RSE) mode. ▪ AI 8 is available on a screw terminal. ▪ +5 V power provided to signal conditioning area of the accessory. <p>Refer to the following figure for a detailed diagram.</p>
	<p>MIO with differential temperature sensor mode—Move switches S1, S2, S3, S4, and S5 to the positions shown at left. In this mode:</p> <ul style="list-style-type: none"> ▪ The temperature sensor can be read using AI 0 and AI 8 in differential mode. ▪ +5 V power provided to signal conditioning area of the accessory. <p>Refer to the following figure for a detailed diagram.</p>
	<p>Direct feedthrough mode—Move switches S1, S2, S3, S4, and S5 to the positions shown at left. In this mode:</p> <ul style="list-style-type: none"> ▪ All 68 signals from the device connect directly to screw terminals. <p>Refer to Using the SCB-68 in Direct Feedthrough Mode for a detailed diagram.</p>
<p>* Not available on Connectors 1, 2, 3 of NI 6225/6255 or NI 6345/6355/6365/6375 devices.</p> <p>† Not available on NI 61xx devices.</p>	

Figure 4. MIO Device Modes Switch Settings



Connecting Signal Sources to Analog Inputs

For detailed information about connections from floating or ground-referenced signal sources to analog inputs, refer to your device documentation.

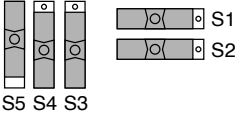
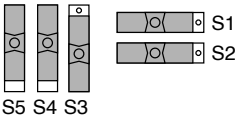
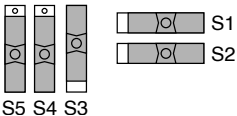
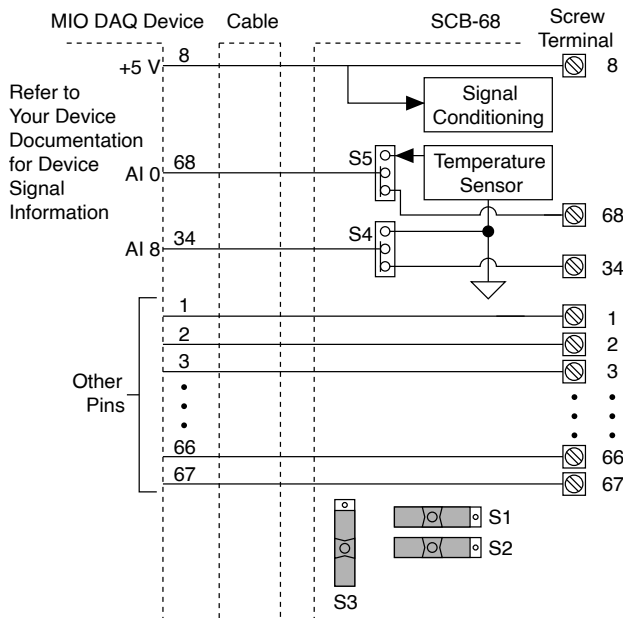
Refer to the **SCB-68 User Manual for Advanced Functions** for more information about using the temperature sensor, taking thermocouple measurements, and adding bias resistors and signal conditioning components to the SCB-68.

Fuse and Power Information

Some DAQ devices provide +5 V power on pin 8 and pin 14. Pin 8 from the DAQ device is protected by an 800 mA, 250 V, 5 × 20 mm fuse on the SCB-68, shown in Figure 2. Shorting pin 8 to ground blows the fuse on the SCB-68. Pin 14 is not fuse-protected on the SCB-68. Shorting pin 14 will cause the fuse on the DAQ device to open.

If the SCB-68 does not work when you power on the DAQ device, check the switch settings, then check the fuse on the SCB-68, shown in Figure 2, and the output fuse (if any) on the DAQ device. Littelfuse part number 235.800 (www.littelfuse.com) is a

suitable replacement fuse. Before replacing any fuses, check for short circuits from power to ground.

Refer to the **SCB-68 User Manual for Advanced Functions** for information about filtering the power on the SCB-68.

Where to Go from Here

Refer to the **SCB-68 User Manual for Advanced Functions**, available from ni.com/manuals, for information about the temperature sensor, thermocouple measurements, bias resistors, soldering components on the SCB-68, filtering, current input measurements, and accessory specifications.